

HI-TEMPERATURE 6E SERIES

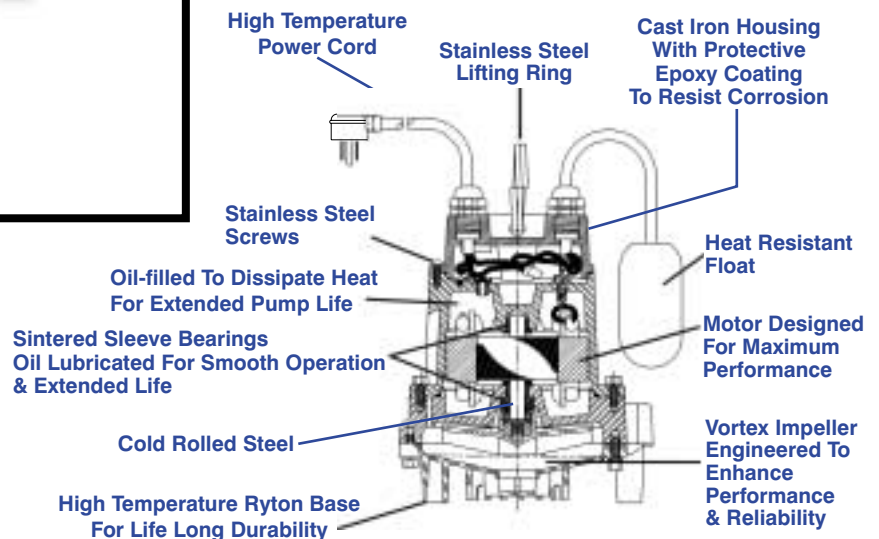

Features

- Handles liquids up to 200° F
- 1/2" Solids handling capability
- Cast iron pump housing with protective epoxy coating for corrosion resistance
- Oil-filled motor housing for lifetime lubrication and rapid heat dissipation
- Stainless steel screws, bolts and lifting ring to protect against corrosion
- Mechanical seals (stainless steel spring, Viton parts, Carbon and Ni-Resist faces) to assure maximum protection against pump failure
- Bearings: Upper and lower sintered sleeve bearings for extended motor life
- Thermal overload protection
- Automatic operation has 10 to 12 "On" level range and 2 to 4 "Off" level range



This high temperature version of the 6E Sump/Effluent Pump is capable of pumping heated liquid up to 200° F. Uses include boiler blow-down sump pits, rendering plant wash-down sump pits, public utility underground transformer vaults, industrial steam cleaning sumps pits, etc. These pumps handle liquids and solid waste materials up to 1/2" in diameter. Pumps feature a 1-1/2" discharge with a lift of 20'. Cast iron housing and volute with protective epoxy coating, Ryton base and vortex nylon impeller.

Little Giant Pump Co.

HI-TEMPERATURE 6E SERIES

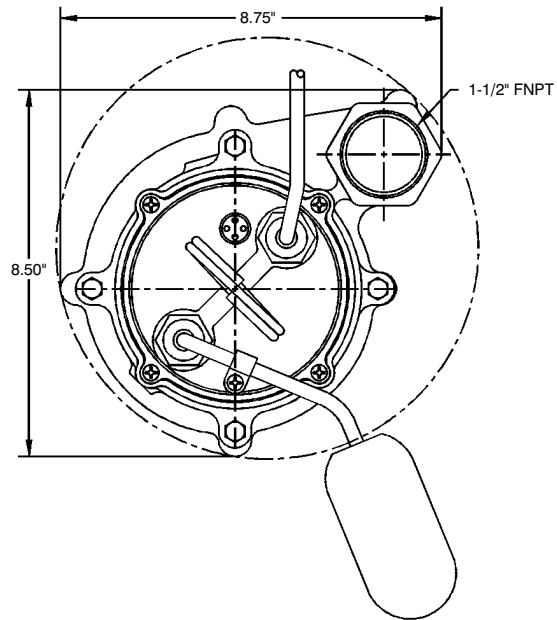
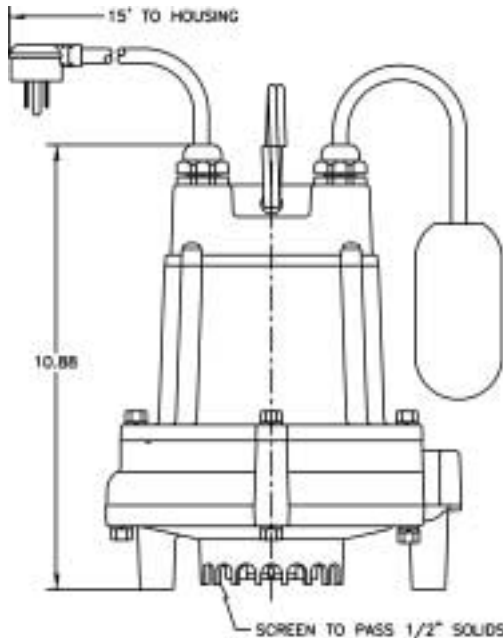

Specifications

MODEL NO.	ITEM NO.	LISTING	SOLIDS SIZE (Dia. In)	VOLTS	HP	RUNNING AMPS/WATTS	GPM PERFORMANCE				SHUT OFF	PSI	PWR. CORD	WEIGHT	DIMENSIONS
							5'	10'	15'	20'					
HT-6E-CIA-FS	506600	CSA	1/2"	115	1/3	10.1/735	50	42	27	20'	8.7	15'	32 LBS	10.88 x 8.75 x 8.5	

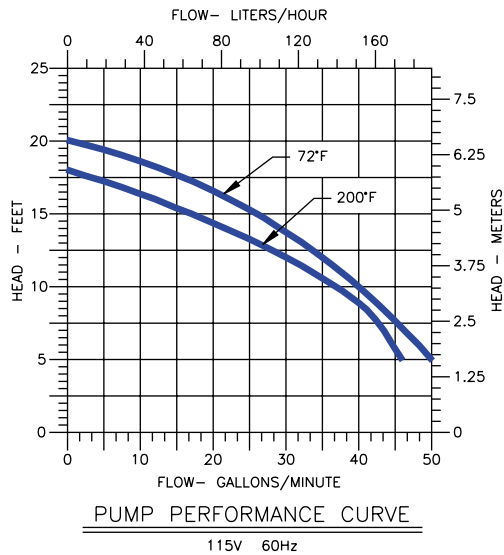

Construction

Motor Housing	Epoxy-coated Cast Iron
Impeller Material	Nylon
Impeller Type	Vortex
Volute	Epoxy-coated Cast Iron
Power Cord	15 , 16-3 SJOW-A, Super Ultron II
Mechanical Shaft Seal	Viton
Fasteners	Stainless Steel
Shaft	Cold Rolled Steel
Bearings	Upper and lower: Oil-impregnated, Porous Iron/Copper, Flanged



ISO 9001 CERTIFIED

Little Giant Pump Co.

PO Box 12010
Okl. City, OK 73157

Phone: 405.947.2511
Fax: 405.951.5674

www.LittleGiantPump.com

Form No. 995602 - 11/99